

Article number: 20193V30B30502SW  
 Description: E+G T-angle clamp  
 GN 193-V30-B30-50-2-SW

## Measures

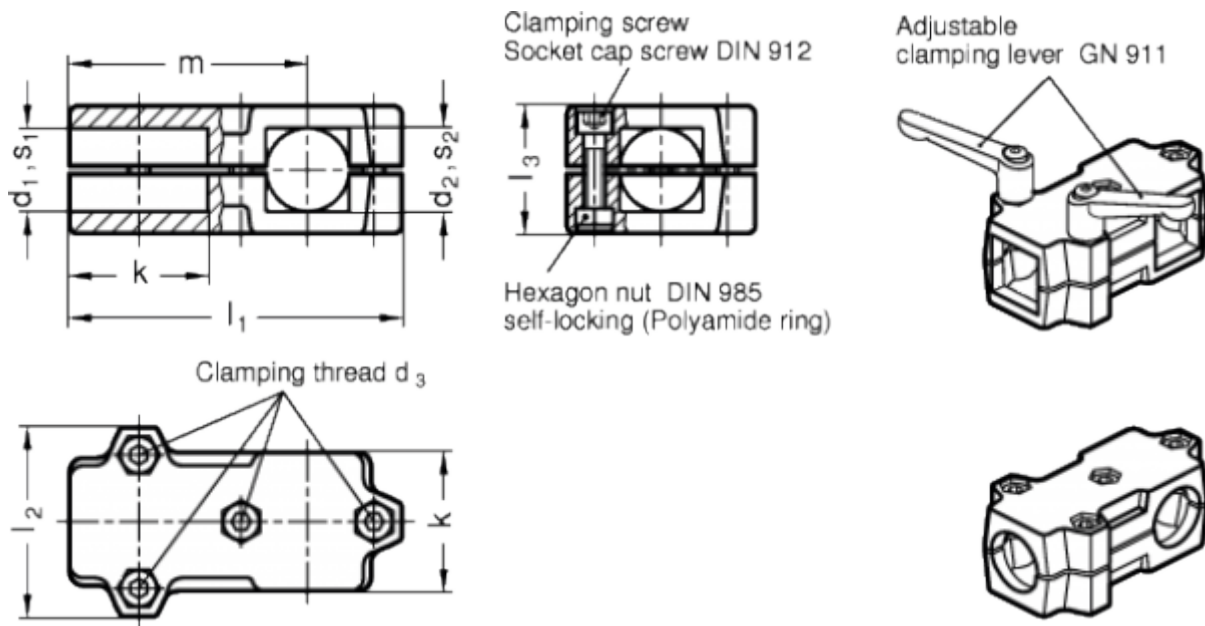

Accessories = GN 911-M8-40	m	= -
d1 = -	s1	= 30
d2 = 30	s2	= -
d3 = M8	Weight in (g)	= 410
k = 50		
l1 = 120		
l2 = 68		
l3 = 46		